



Diaphragm seal MD 81 Tubus flange version



Benefits

- For tanks with thick walls
- For higher block flanges and increased insulation
- Connection as per DIN or ASME
- Tubus length can be adapted as required

Application

For mounting to Bourdon tube pressure gauges, pressure transducers or pressure switches. For corrosive, highly viscous, polluted, crystallising or hot media. Ideal for insulated or thick-walled tanks. Specially designed for use in the chemical and petrochemical industries, in refineries or power plant engineering.

Versions

flange connection as per ASME B 16.5 (Raised Face)

	Process connection	Instrument connection	Nominal pressure	Minimum range* (in bar) at nominal size				Part no.
				63	100	160	DMU	
	1"	Welded connection	CL 150	4 bar	4 bar	–	1 bar	31938W
	2"	Welded connection	CL 150	1 bar	2.5 bar	–	1 bar	31929W
	3"	Welded connection	CL 150	0.6 bar	0.6 bar	1 bar	1 bar	31931W

Blue part no. = in-stock items

flange connection as per EN 1092-1 type B 1

	Process connection	Instrument connection	Nominal pressure	Minimum range* (in bar) at nominal size				Part no.
				63	100	160	DMU	
	DN 50	Welded connection	PN 40	1 bar	2.5 bar	–	1 bar	31917W
	DN 80	Welded connection	PN 40	0.6 bar	0.6 bar	1 bar	1 bar	31921W
	DN 100	Welded connection	PN 40	0.6 bar	0.6 bar	1 bar	1 bar	31924W

Blue part no. = in-stock items



Technical specifications

Process connection/tubus

Stainless steel 316 L

Flange connection

as per ASME B 16.5

(Raised Face) or as

per EN 1092-1 type B

1

Tubus length: 50 mm

Diaphragm

Stainless steel 316 L

Welded

Sealing surface

Stainless steel 316 L

Instrument connection

Welded connection

Pressure transmission liquid

Paraffin oil (FM 09), FDA-listed

Pressure range

See ordering table

Nominal pressure

CL 150, PN 40

Options

Other

- Other nominal diameters

Technical drawings

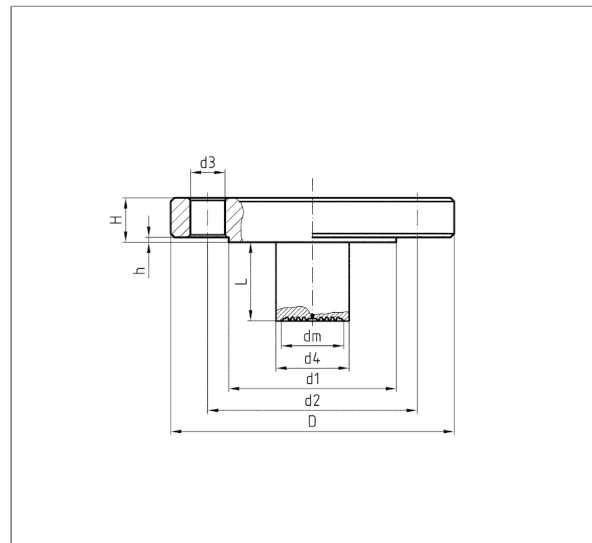
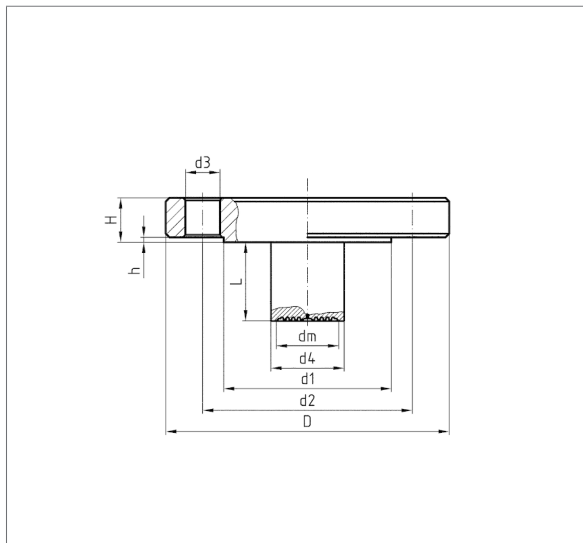

DN	CL	D	d1	d2	d3	d4	H	h
1"	150	108	51	79,5	4x16	25	14,5	1,5
2"	150	152	92	121	4x19	48	19	1,5
3"	150	190	127	152	4x19	76	24	1,5

DN	PN	D	d1	d2	d3	d4	H	h
50	40	165	102	125	4x18	48	20	3
80	40	200	138	160	8x18	76	24	3
100	40	235	162	190	8x22	94	24	3